

## Overview

---

Camera, and microphone remote collaboration device.



## Features

---

- Newly developed SoundCap Eye
- 4K Camera with Smart Framing
- One-USB connection to start the collaboration
- Engineered Adaptive echo canceller and Noise reduction
- Hexa-microphone Beamforming
- Iconic mute button of remote control
- Multiple installation options

## Specifications

1/2

### General Specifications

Description	Video Conference System	
Dimensions (W x D x H)	W261 mm x D76 mm x H51 mm	
Weight	0.6 kg	
Power Requirements	AC 100 - 240 V (50/60 Hz)	
Maximum Power Consumption	15.0 W	
Safety	CB/G, UL, CE, RCM, KC, CCC*, BSMI*, BIS*	
EMC	FCC, IC, CE, RCM, KC, CCC*, BSMI*	
Radio Interference Standard	FCC, IC, CE, RCM, KC, SRRC*, NCC*, ANATEL	
In Operation	Temperature	0°C - 40°C
	Humidity	20% - 85% (no condensation)
Storage	Temperature	-20°C - 60°C
	Humidity	20% - 85% (no condensation)
Indicator	Status Indicator	
Accessories	Read this first, Safety Guide, USB 2.0 cable (Type C-A, 5 m / 16.4 ft), HDMI cable (2 m / 6.6 ft), Remote control (RC-RBT1), Lens cap, Coin battery (CR2032) x 2, AC adaptor with power cord (CW2002100), Cable tie	
Options	Mounting Accessory BRK-WL1, Mounting Accessory BRK-TV1, USB 3.2 Gen 2 cable (A-C) 10 m CBL-L10AC, USB 3.2 Gen 2 cable (A-C) 25 m CBL-L25AC	
Supported OS	Windows 11, Windows 10, macOS 12, macOS 11, macOS 10.15, Chrome OS	
Installation	Installation above display (thickness up to 50 mm): Embedded leg Installation above display (rigid): BRK-WL1 and BRK-TV1 (options) Installation below display: BRK-WL1 and BRK-TV1 (options) Wall mount installation: BRK-WL1 (option) Tripod installation: Embedded tripod screw hole	

\* Tentative

### Connections

USB Type-C	USB 2.0/3.2 Gen 1, UAC 2.0, UVC 1.1, DisplayLink		
HDMI	Version 1.4		
	Resolution: 720 x 480, 1280 x 720, 1366 x 768, 1920 x 1080 Frame Rate: 30 fps HDCP: Version 1.4 HDMI-CEC: Power control, Input selection		
3.5 mm Audio Jack	Headphone / Line output (Stereo out)		
Bluetooth	Common	Version 5.0	
		Supported Profiles: HFP (1.7), A2DP, AVRCP, BLE	
		Supported Codec: CVSD, SBC, mSBC	
		Wireless Output: Class 1	
		Maximum Communication Distance: 10 m (32.8 ft) (no obstacles) Radio Frequency (Operational Frequency): 2,402 to 2,480 MHz	
	U.K./EU	Maximum Output Power (EIRP): 7.0 dBm (5.0 mW)	
	USA/Canada	Maximum Output Power: 7.79 dBm (6.0 mW)	
	Korea	Maximum Output Power: 0.003 W	
Wi-Fi Network	Common	Wireless LAN Standards: IEEE 802.11b/g/n	
		Radio Frequency Band: 2.4 GHz	
		Available Security Method: OPEN, WEP, WPA/WPA2-PSK, WPA3-SAE	
		U.K./EU	Radio Frequency (Operational Frequency): 2,412 to 2,472 MHz Maximum Output Power (EIRP): 18.7 dBm (74.1 mW)
		USA/Canada	Radio Frequency (Operational Frequency): 2,412 to 2,462 MHz Maximum Output Power: 13.81 dBm (24.0 mW)
	Korea	Radio Frequency (Operational Frequency): 2,412 to 2,472 MHz Maximum Output Power: 0.01 W/MHz	

## Specifications

2/2

### Audio

Microphone	Hexa-microphone (6 x MEMS)
Microphone Coverage	120 degrees audio pickup Max Distance: 6.0 m (19.6 ft, Face focus beamforming off) / 3.0 m (9.8 ft, Face focus beamforming on)
Microphone Frequency Response	100 Hz - 16 kHz
Audio Processing	Adaptive echo canceller, Noise reduction, Automatic tracking, Automatic gain control, Automatic room EQ, Dereverberation, SoundCap Eye (Face focus beamforming, Self-silence, Self-volume balancer)

### Camera and Video

Sensor	CMOS 8M pixel (4K)
Diagonal Field of View	120 degrees
Focus Distance	0.5 m (1.6 ft) to ∞
Frame Rate	6 fps, 7.5 fps, 10 fps, 15 fps, 30 fps
Supported Video Resolution	3840 x 2160 2560 x 1440 1920 x 1080 1280 x 720 640 x 360
Supported Video Codec	YUY2, MJPEG, NV12
Frame Control	Smart framing (Group, Individual, Speaker tracking) or manual pan-tilt-zoom (PTZ), configurable preset x 2 Maximum Zoom Ratio: 5.0x People Detection Max Distance: 4.5m
Video Processing	Automatic white balancing, Automatic exposure control, Noise reduction

### User Interface

Function Button	Factory default setting, Remote control pairing
Remote Control	Power, Microphone mute x 2, Speaker volume, Camera ePTZ, Smart framing ON/OFF, Camera preset x 2, OSD menu control
OSD Menu	Meeting area, Smart framing mode, Camera preset, Mic, Speaker, Bluetooth
People Detection	Auto wake-up
Yamaha CS Manager	Supported OS: Windows 11, Windows 10 (64 bit), macOS 12, macOS 11, macOS 10.15 Functions: Device status monitor, Security setting, Power setting, Audio setting, Camera setting, Smart framing setting, Bluetooth setting, HDMI screen setting, Network (Wi-Fi) setting, NTP setting, Firmware upgrading, Factory default setting, Logs retrieving

### Output Characteristics

Output Terminal	Type	Actual Source Impedance	For Use with Nominal	Output Level	Connector
3.5 mm mini-Jack	Headphone	20 Ω	16 - 32 Ω	25 mW (16 Ω)	3.5 mm stereo (TRS)
	Line		100 Ω	0.8 dBV	

**Dimensions**

**1/3**

Unit: mm (inch)

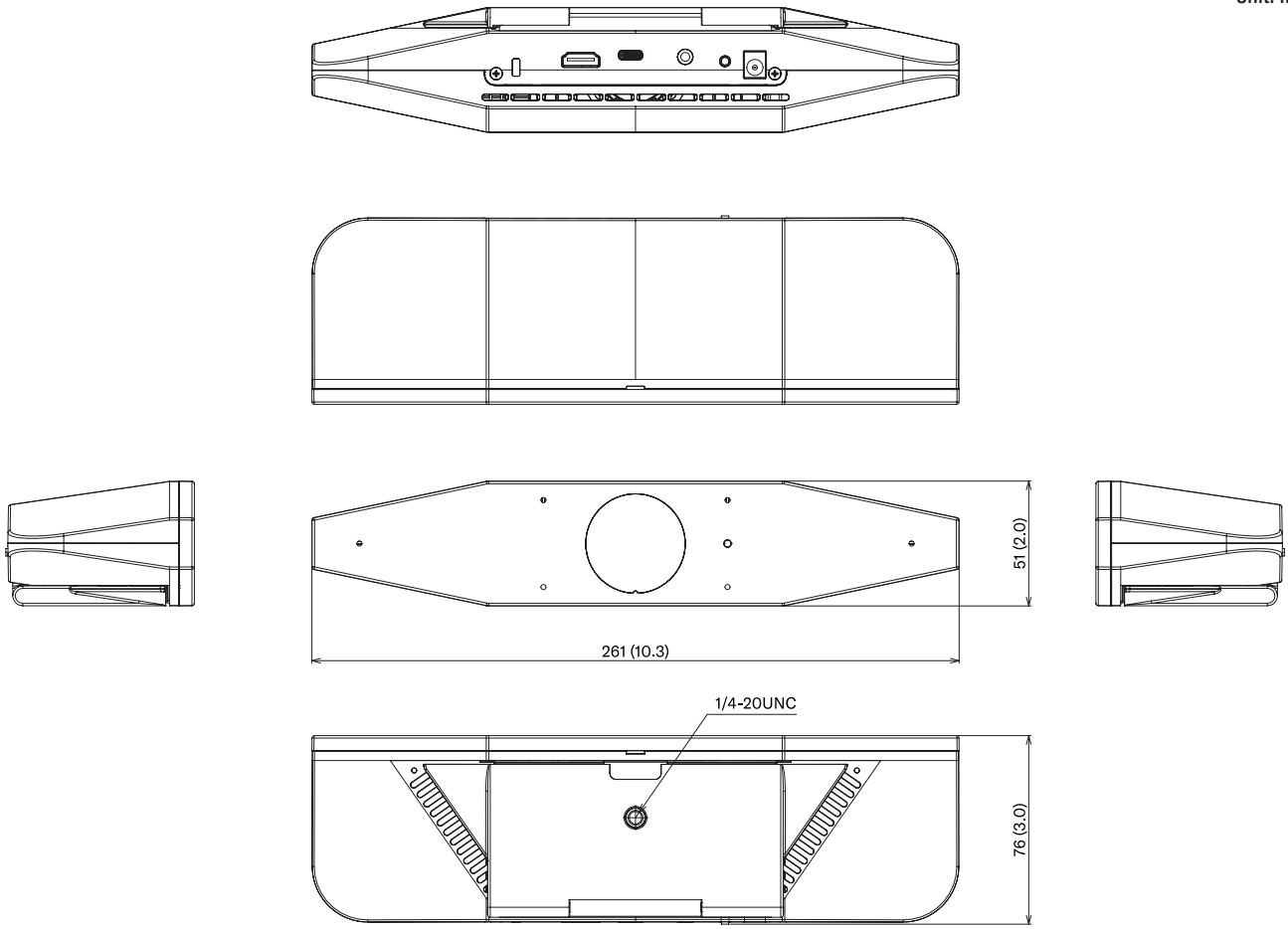

**Dimensions**

Unit: mm (inch)

**BRK-WL1**

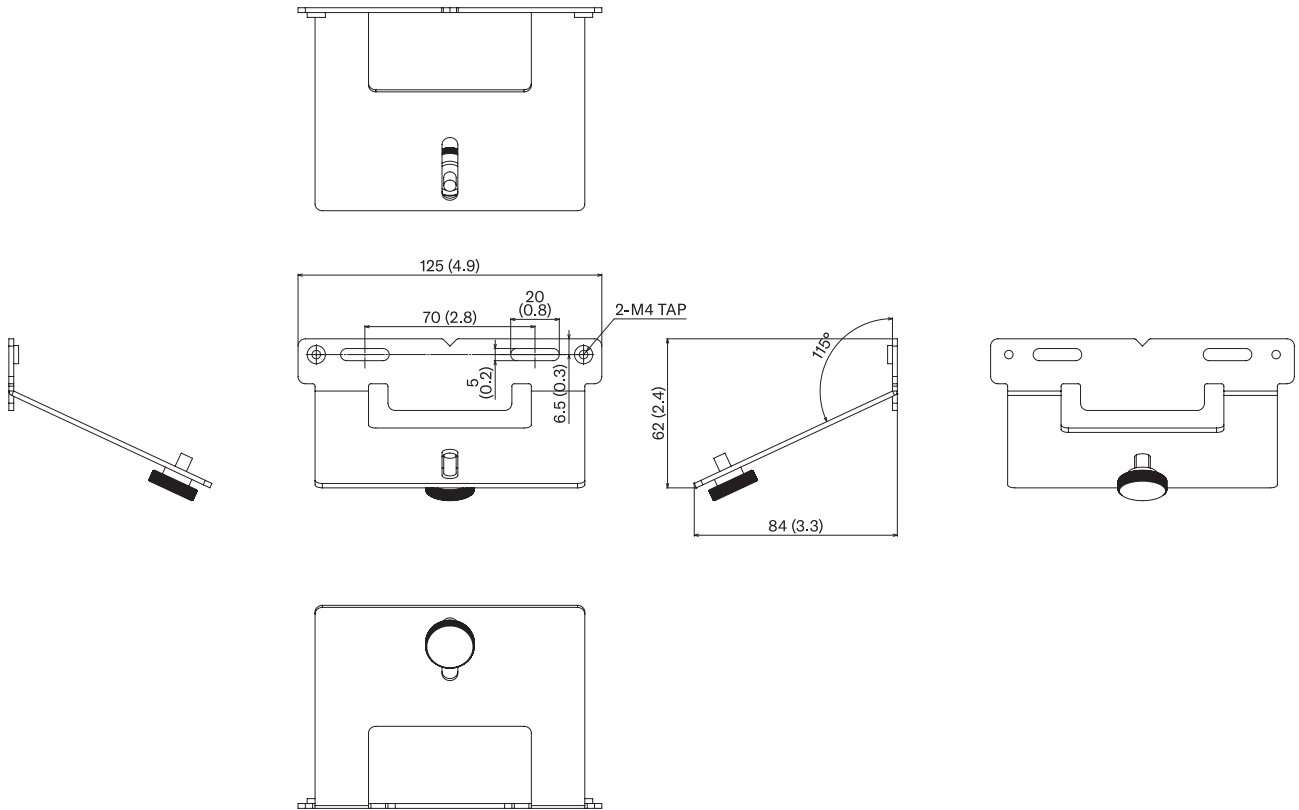

**Dimensions**
**3/3**

Unit: mm (inch)

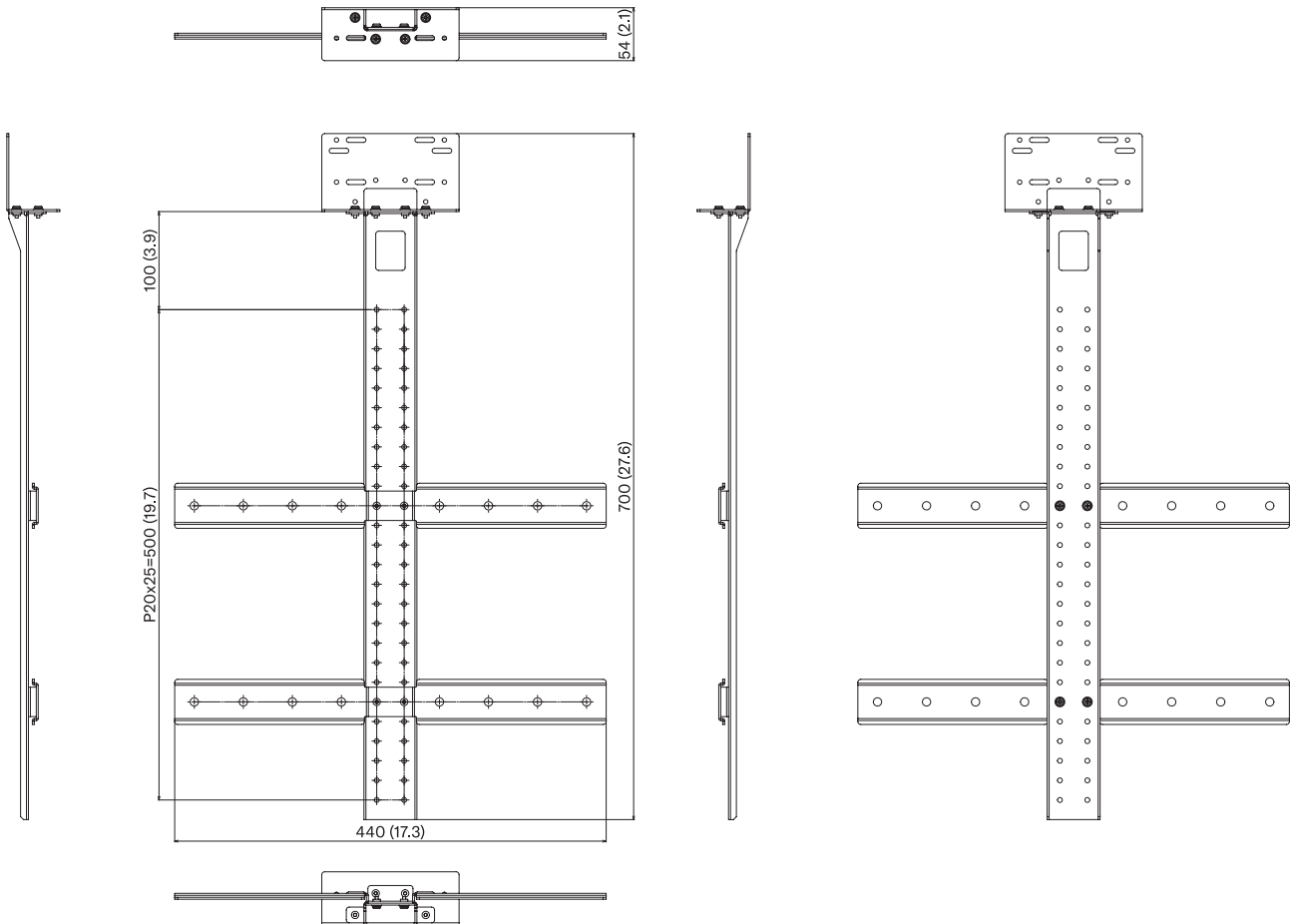
**BRK-TV1**

**Options**

- Wall Mounting Bracket BRK-WL1
- Monitor Mounting Bracket BRK-TV1
- USB Cable (10 meters) CBL-L10AC
- USB Cable (25 meters) CBL-L25AC

**Software**

- Yamaha CS Manager

## Architectural and Engineering Specifications

---

The Yamaha CS-500 shall be an integrated video conference system for huddle spaces. The CS-500 shall comprise an 8-megapixel (4K) camera, six MEMS microphones, versatile connectivity (USB Type C, HDMI, Bluetooth, and Wi-Fi), an analog audio output connector, and an easy-to-use interface that provides access to features and functions designed to deliver a seamless, efficient video conferencing experience in a broad range of office environments. The CS-500 shall be supplied with a wireless remote control unit that provides direct access to essential functions. A multi-color status indicator LED on the front panel shall provide essential status monitoring. The CS-500 shall be ideally suited for use in rooms up to 6 meters (19.6 feet) in depth.

The 4K camera shall have a 120-degree field of view and a focus range of from 0.5 meters (1.6 feet) to infinity. Maximum zoom ratio shall be 5x, and framing shall be controllable either automatically by software (group, individual, or speaker tracking) or manual PTZ buttons on the supplied remote control unit. Buttons to save and recall two sets of PTZ settings shall be provided on the remote control unit. White balance, exposure, and noise reduction shall be automatic. The camera shall support frame rates of 6, 7.5, 10, 15, and 30 frames per second, and video resolutions of 3840 x 2160, 2560 x 1440, 1920 x 1080, 1280 x 720, and 640 x 360.

The CS-500 shall pick up sound via an array of six MEMS microphone units, using face focus beamforming technology to focus on the speaker while rejecting unwanted sound. Microphone pickup shall cover an angle of 120 degrees up to a maximum distance of 6 meters (19.6 feet) when face focus beamforming is OFF, or 3 meters (9.8 feet) when face focus beamforming is ON. Microphone frequency response shall be from 100 Hz to 16 kHz. Audio processing functions available for sound pickup shall include adaptive echo cancellation, noise reduction, automatic tracking, automatic gain control, automatic room EQ, dereverberation, and SoundCap Eye (including face focus beamforming, self-silence, and self-volume balancing).

The CS-500 shall be supplied with a wireless remote control unit having the following functions: Power, microphone mute x2, speaker volume, camera PTZ control, smart framing ON/OFF, camera preset x2, and on-screen display menu control.

Connection between the CS-500 and the host computer shall be made via a single USB cable that will transfer camera and microphone data from the CS-500 to the computer and audio output data back to the CS-500 for output via its built-in speaker. Connection from the CS-500 to the main display device (HDMI equipped TV or monitor) shall be made via a single HDMI cable. DisplayLink driver software for Windows computers and DisplayLink Manager software for MacOS computers shall allow the computer display to be shown on a TV screen via the CS-500 in systems that use an HDMI equipped TV rather than a dedicated computer display. Detailed CS-500 settings shall be edited and monitored via the Yamaha CS Manager application installed on the host computer. The CS Manager application shall be compatible with major current computer operating systems.

Built-in Bluetooth shall allow a computer or mobile device brought in by a user to be wirelessly connected to the CS-500 so that it can be configured via the connected display device (HDMI equipped TV or monitor) and on-screen display facility. A Bluetooth connection can also be used to allow a local mobile device (tablet or smartphone) to call a remote mobile device user into the conference in audio-only mode. The ability to connect to a network via Wi-Fi shall allow the CS-500 to keep accurate time.

Audio output from the video conference system shall be delivered via an audio system connected to the 3.5 mm analog audio output jack on the rear of the CS-500 or via an audio system connected directly to the host computer.

The CS-500 shall be supplied with a stand that allows the unit to be mounted on top of a TV or monitor. An optional wall mounting bracket and screen mount bracket shall allow the CS-500 and TV or monitor to be mounted on a wall. The main CS-500 unit shall be powered by a supplied external power adapter, and the remote control unit shall be powered by two CR-2032 coin batteries. Dimensions shall be 261 (W) x 51 (H) x 76 (D) mm. Weight shall be 0.6 kg.

\*All information subject to change without notice.

\*All trademarks and registered trademarks are property of their respective owners.

Created in August, 2022

**YAMAHA CORPORATION**  
P.O.BOX 1, Hamamatsu Japan